



# Float Valve Switch



- All 304 stainless steel construction.
- Polished float ball.
- Pressure range up to 10 Bar. 20 Bar Upon Request
- Silicone/EPDM seat.
- Working temperature up to 80°C.
- Fullbore for high flow.
- Connections in Thread or Flanged.

- ▶ Size Range: DN15 (1/2") - DN80(3")
- ▶ Temperature Range: 0°C ~ 80°C
- ▶ Connections : DN10 - DN25 (Threaded)  
DN40 - DN80 (Threaded)

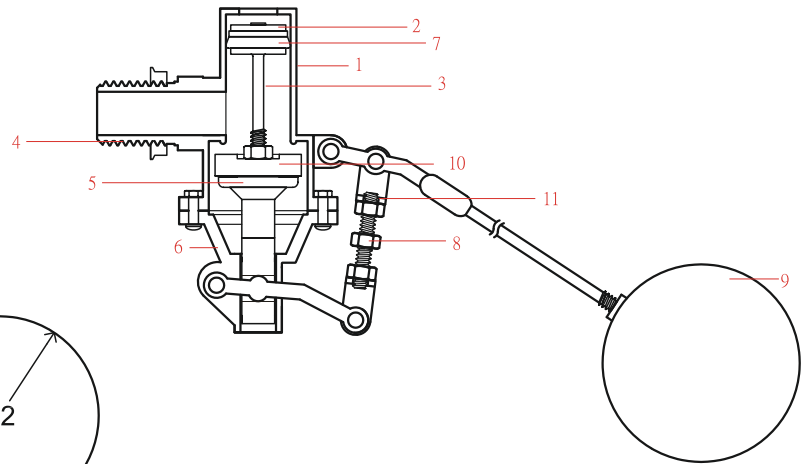
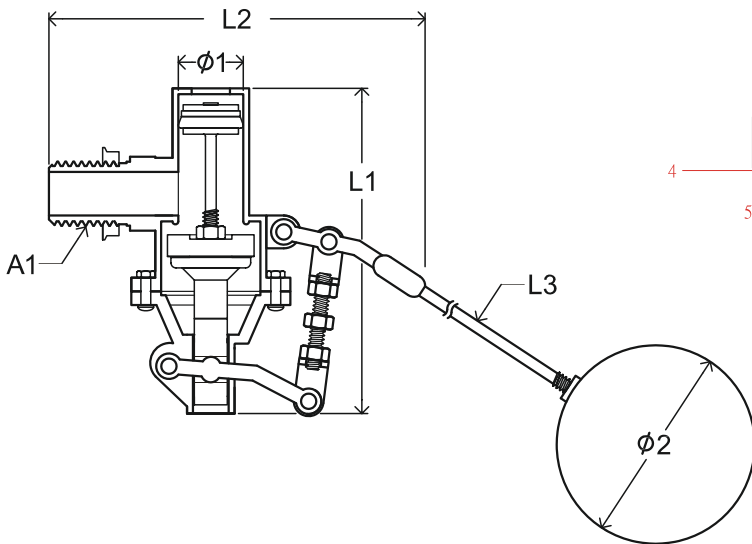

Table of Valve Size (mm)				SS304 Float Ball		
A1 G Threaded	L1	L2	Ø1	L3	Ø2	Weight(kg)
1/2"	110	133	20	160	100	0.67
3/4"	110	145	20	160	100	0.72
1"	110	145	20	160	100	0.76
1 1/2"	170	120	30	350	150	1.75
2"	210	130	40	400	150	2.42
3"	240	160	60	420	200	5.67

No	Part Name	Material
1	Main Body	Stainless Steel 304
2	Piston(Shaft)	Stainless Steel 304
3	Shaft	Stainless Steel 304
4	Orifice	Stainless Steel 304
5	Valve Gate	Stainless Steel 304
6	Lifting Gear	Stainless Steel 304
7	U-Ring	EPDM/Silicone
8	Adjusting Screw	Stainless Steel 304
9	Float Ball	Stainless Steel 304
10	U-Ring	EPDM/Silicone
11	Screw U-Ring	EPDM/Silicone